



## AWT2-3927

**Common Name** 36 Port (4P/8P x 3) 3.6M Low Band, Mid Band Modular Tri-Sector, T2 Series.

612-894MHz	12	eRET	14.6	70°
1695-2690MHz	24	eRET	17.8	65°
Frequency	Ports	Tilt	Gain	Beamwidth

## PRODUCT INFORMATION

Stack	Part Name	Description
1	Base Stack	The Base Stack contains Low Band and Mid Band sectors. There is a Mount Plate located on the bottom of the Base Stack to attach to the Monopole.
2	Extension Stack	The Extension stack contains Low Band and Mid Band sectors.

The Modular Tri-Sector T2 Series is a flexible antenna platform designed for Streetwork deployments. The AWT2 Platform is made up using discrete parts. The AWT2-3927 consists of two modular antenna stacks which are detailed in the table below:

Stack Type	Frequency Bands	Ports per Stack
Base Stack	612-894MHz	6
	1695-2690MHz	12
Extension Stack	612-894MHz	6
	1695-2690MHz	12

Each stack is made up of three panels that are positioned at 0°, 120° and 240° in the Azimuth plane. These individual panels are replaceable in the field for upgrade or maintenance purposes.

**Note #1:** The Alpha Wireless AWT2 series can only support a single Base Stack and a single Extension Stack. The Alpha Wireless AWT4 series can support a single Base Stack and up to three Extension Stacks.

**Note #2:** Both the AWT2 and AWT4 have a mounting plate to enable mounting number of Active Antenna units on top, weight permitting.

## APPLICATION

Sector antennas support multiple antennas into one attractive package. These canisters deliver an elegant macro solution for pole-top, rooftop and streetworks applications. Alpha Wireless produces one of the smallest diameter canisters in the marketplace.

## STANDARD &amp; CERTIFICATIONS

Certification	BS EN ISO 9001:2015
---------------	---------------------



The parameters in this specification follow the definitions and recommendations per NGMN P-Basta, Release 9.6.

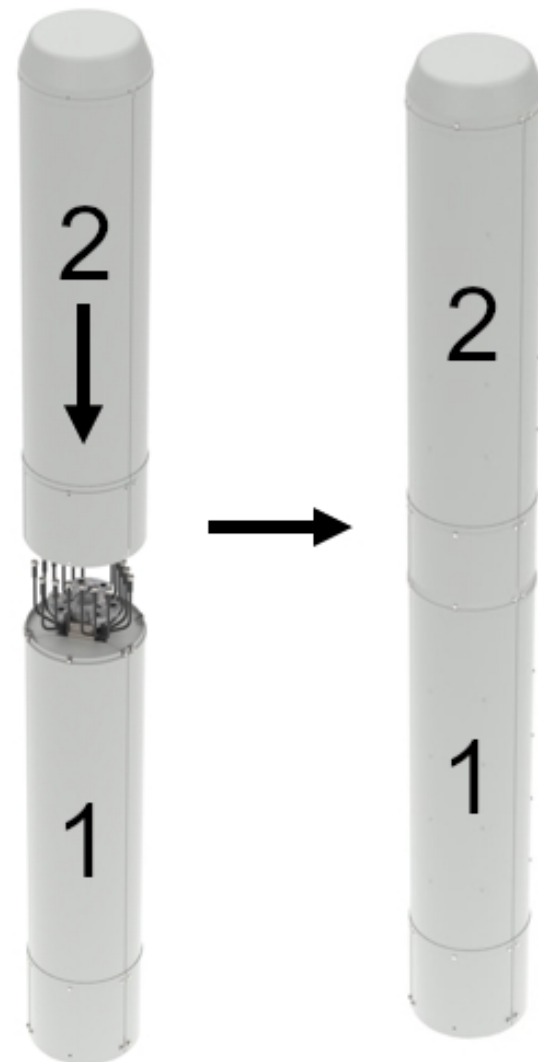

## FEATURES

- The AWT2 Series supports up to two modular stacks.
- Field upgradable sectors without decommissioning the other sectors.
- Three sector canister with sectors orientated at 0°, 120° and 240° in the Azimuth Plane
- 612-894MHz x 2 Ports per sector.
- 1695-2690MHz x 4 Ports per sector.
- 612-894MHz tilt range T2° - T12°.
- 1695-2690MHz tilt range T2° - T12°.
- Low PIM performance to reduce interference.

## TECHNICAL SPECIFICATION

Electrical Specifications		Low Band			Mid Band			
Frequency Range	MHz	612-707	707-802	802-894	1695-1920	1920-2170	2300-2690	
Polarisation	Degree	+/- 45° Slant Linear						
Gain	Basta	dB	13.1±0.5	13.8±0.5	14.1±0.5	16.8±0.5	17.1±0.5	17.0±0.5
	Max	dB	13.6	14.3	14.6	17.3	17.6	17.5
Azimuth Beamwidth	Degree	76°	77°	77°	64°	67°	66°	
Elevation Beamwidth	Degree	18.1°	15.5°	14.0°	7.2°	6.5°	5.5°	
Electrical Downtilt	Degree	T2° - T12°			T2° - T12°			
Electrical Downtilt Deviation	Degree<	1.5°	1.5°	1.5°	1°	1°	1°	
Impedance	Ohms	50						
VSWR	<	1.5						
Return Loss	dB>	14						
Isolation	dB>	25	25	25	25	25	25	
Passive Intermodulation	dBc<	-150	-150	-150	-150	-150	-150	
Upper Sidelobe Suppression, Peak to 20°	dB>	16	16	16	15	15	15	
Cross-Polar Discrimination	dB>	15	15	15	15	15	15	
Max Power Per Port	W	300			250			

## Radiation Pattern Files

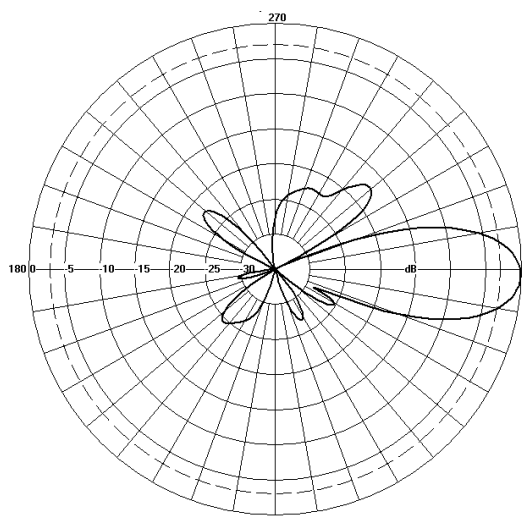
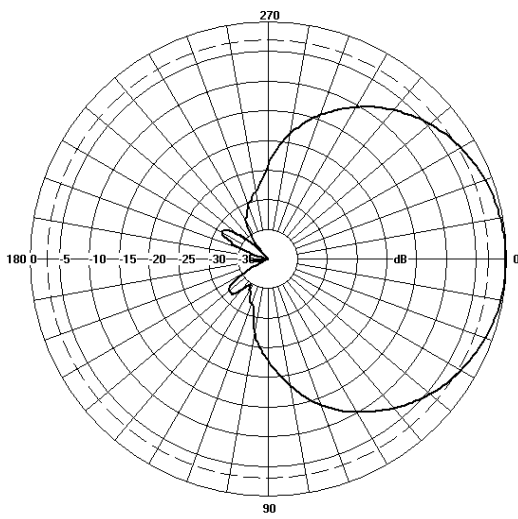

Low Band

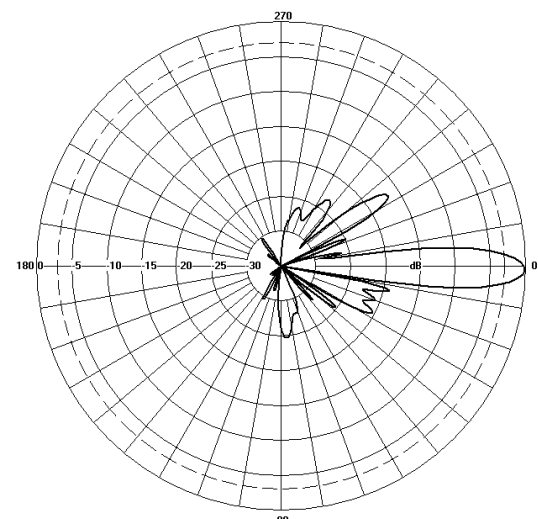

Mid Band

Azimuth

Elevation

For radiation pattern files, please login at [www.alphawireless.com](http://www.alphawireless.com)

## TECHNICAL SPECIFICATION

## Mechanical Specifications

Dimensions Base + Extension(s) (Length x Diameter)	mm (in)	3615 (142.3) x 406 (16) - (L x Ø)
Dimensions Base (Length x Diameter)	mm (in)	1911 (75.3) x 406 (16) - (L x Ø)
Dimensions Extension (Length x Diameter)	mm (in)	1704 (67.0) x 406 (16) - (L x Ø)
Weight of Base Stack	kg (lb)	96.5 (212.3)
Weight of Extension Stack	kg (lb)	74.5 (163.9)
Total Tri-Sector Weight	kg (lb)	171 (377)
Connector Type (Female)	-	4.3-10
Connector Position	-	Bottom
Connector Quantity	-	36 (12P Low Band, 24P Mid Band)
Windload Frontal (at Rated Wind Speed: 150km/h)	N (lbf)	1194 (270)
Windload Lateral (at Rated Wind Speed: 150km/h)	N (lbf)	1194 (270)
Survival Wind Speed	km/h (mph)	200 (125)
Radome Material	-	UV Stabilised ASA capped ABS
Radome Colour	RAL	7035 (light grey)
Product Compliance Environmental	-	RoHS
Lightning Protection	-	DC Grounded
Cold Temperature Survival	°C (°F)	-40° C (-40° F)
Hot Temperature Survival	°C (°F)	70° C (158° F)
<b>Shipping Information</b>	-	-
Size of Crate Type 1 - Base Stack and Interface (LxWxD)	mm (in)	2100 (82.6) x 570 (22.4) x 628 (24.7)
Size of Crate Type 2 - Extension Stack (LxWxD)	mm (in)	2100 (82.6) x 570 (22.4) x 628 (24.7)
Shipping Weight of Crate Type 1 - Base Stack	kg (lb)	149 (327.8)
Shipping Weight of Crate Type 2 - Extension Stack	kg (lb)	127 (279.4)
Total Number of Crates (Types 1 and 2)	Quantity	1 x Type 1, 1 x Type 2

## Array Layout and RET Information

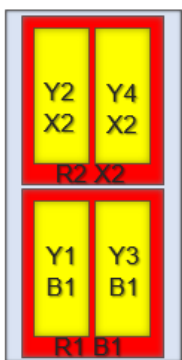

Note: Coloured box sizes do not represent antenna sizes.

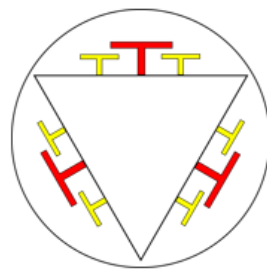

<b>Configuration</b>	
698-960 MHz	One RET per array: R1, R2 x 3 Sectors
1710-2690 MHz	One RET per array: Y1, Y2, Y3, Y4 x 3 Sectors
Total Quantity	Eighteen RET Motor Controllers
<b>Location and Interface</b>	
RET Controller Location	Inside antenna radome housing
RET Interface	Pair of AISG 8 Pin DIN connectors, one male, one female
RET Interface Quantity	Three pairs of AISG 8 Pin DIN connectors, one per sector
RET Interface Location	On connector plate located at bottom of antenna
<b>Electrical</b>	
Input Voltage	10 - 30V
Power Idle Mode	< 1W
Power Active Mode	< 10W
Protocol	3GPP / AISG 2.0

Stack	Sector	Array	Frequency MHz	Ports	RET ID	AISG Serial Number Format
X2	S1	R2	612 - 894	1 - 2	1	ASXXXXXXXXX2S1R2
X2	S1	Y2	1695 - 2690	3 - 4	2	ASXXXXXXXXX2S1Y2
X2	S1	Y4	1695 - 2690	5 - 6	3	ASXXXXXXXXX2S1Y4
B1	S1	R1	612 - 894	1 - 2	4	ASXXXXXXXXX1S1R1
B1	S1	Y1	1695 - 2690	3 - 4	5	ASXXXXXXXXX1S1Y1
B1	S1	Y3	1695 - 2690	5 - 6	6	ASXXXXXXXXX1S1Y3
X2	S2	R2	612 - 894	1 - 2	7	ASXXXXXXXXX2S2R2
X2	S2	Y2	1695 - 2690	3 - 4	8	ASXXXXXXXXX2S2Y2
X2	S2	Y4	1695 - 2690	5 - 6	9	ASXXXXXXXXX2S2Y4
B1	S2	R1	612 - 894	1 - 2	10	ASXXXXXXXXX1S2R1
B1	S2	Y1	1695 - 2690	3 - 4	11	ASXXXXXXXXX1S2Y1
B1	S2	Y3	1695 - 2690	5 - 6	12	ASXXXXXXXXX1S2Y3
X2	S3	R2	612 - 894	1 - 2	13	ASXXXXXXXXX2S3R2
X2	S3	Y2	1695 - 2690	3 - 4	14	ASXXXXXXXXX2S3Y2
X2	S3	Y4	1695 - 2690	5 - 6	15	ASXXXXXXXXX2S3Y4
B1	S3	R1	612 - 894	1 - 2	16	ASXXXXXXXXX1S3R1
B1	S3	Y1	1695 - 2690	3 - 4	17	ASXXXXXXXXX1S3Y1
B1	S3	Y3	1695 - 2690	5 - 6	18	ASXXXXXXXXX1S3Y3

TECHNICAL SPECIFICATION

Mechanical Illustration

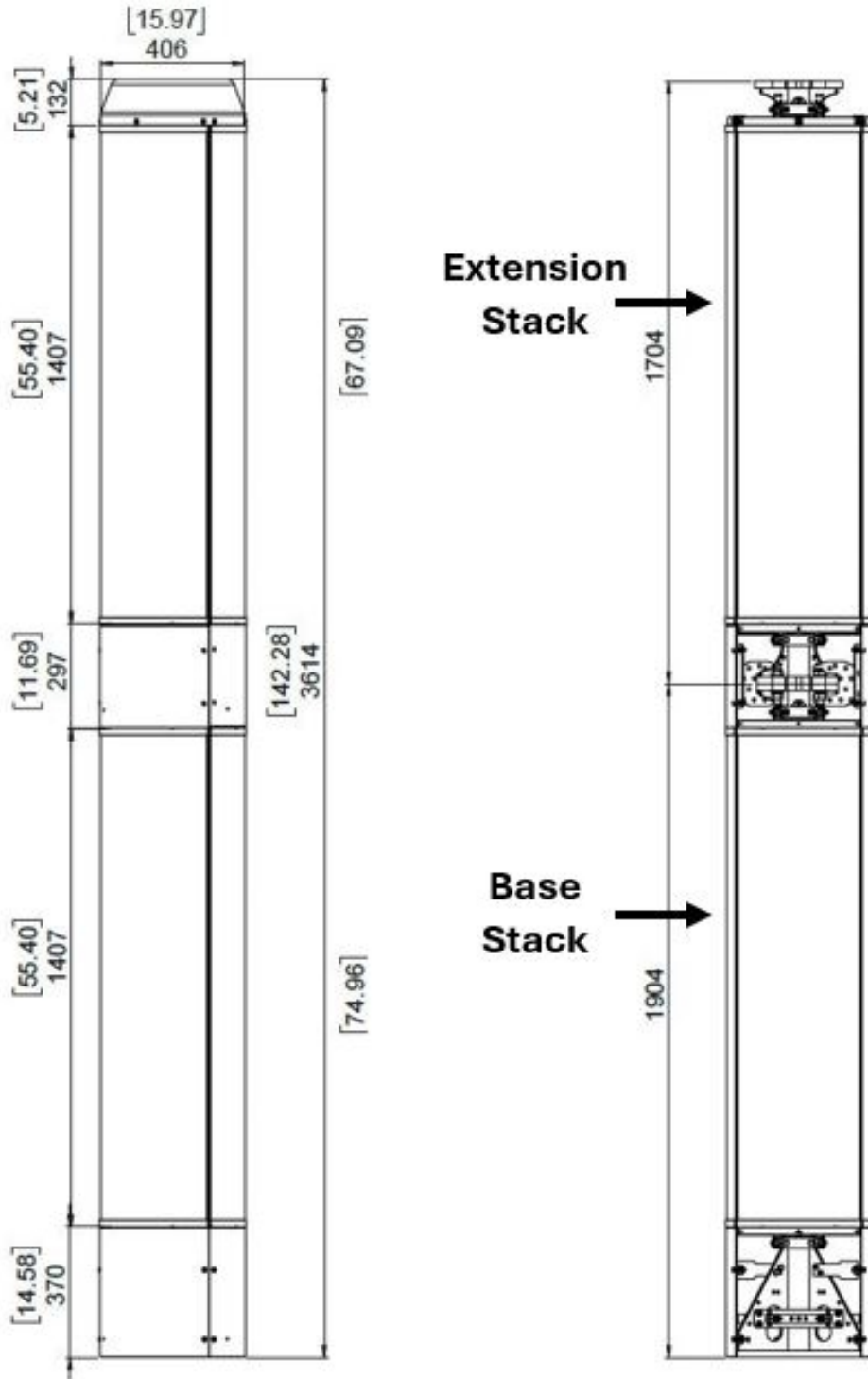

Description of Parts

Base Stack	This contains the Antenna Sectors. Mounted onto the Base Stack Interface. The top of the Base Stack has a mounting flange onto which the Extension Stack is mounted.
Extension Stack	This contains the Antenna Sectors. Mounted onto the Base Stack . The bottom of the Base Stack has a mounting flange onto which the Extension Stack is mounted to the base stack.
RF Jumpers Base Stack	Feeders from the Radio Cabinet feed directly into the connectors located at the bottom of the Base Stack.
RF Jumpers Extension Stack	RF Jumpers are routed behind the Base Stack Radomes.

TECHNICAL SPECIFICATION

Connector Plate Images

<p>The image shows a semi-circular connector plate with six ports. The top row of ports is labeled '698-960MHz' and includes: Y1 (ports 3 and 4, +45° and -45°), R1 (ports 1 and 2, +45° and -45°), and Y2 (ports 5 and 6, +45° and -45°). The bottom row of ports is labeled '1710-2690MHz' and includes: L, IN, C, OUT, and R. A central control panel with a switch and indicator lights is located below the ports.</p>	<p>Showing Low Band / Mid Band Connector Plate located at bottom of Extension Stack.</p>
<p>The image shows a rectangular metal component, the RET Motor Cartridge, with two circular ports and four screws on its surface.</p>	<p>Each RET Motor is located at the bottom of each antenna sector as part of the Connector Plate. Each RET motor can be accessed individually and if necessary replaced individually by releasing two screws and sliding out the RET Motor Cartridge. A new RET Motor Cartridge can be slid back in as replacement.</p>

## TECHNICAL SPECIFICATION

### Mounting Bracket Kit

3 inch Bracket description

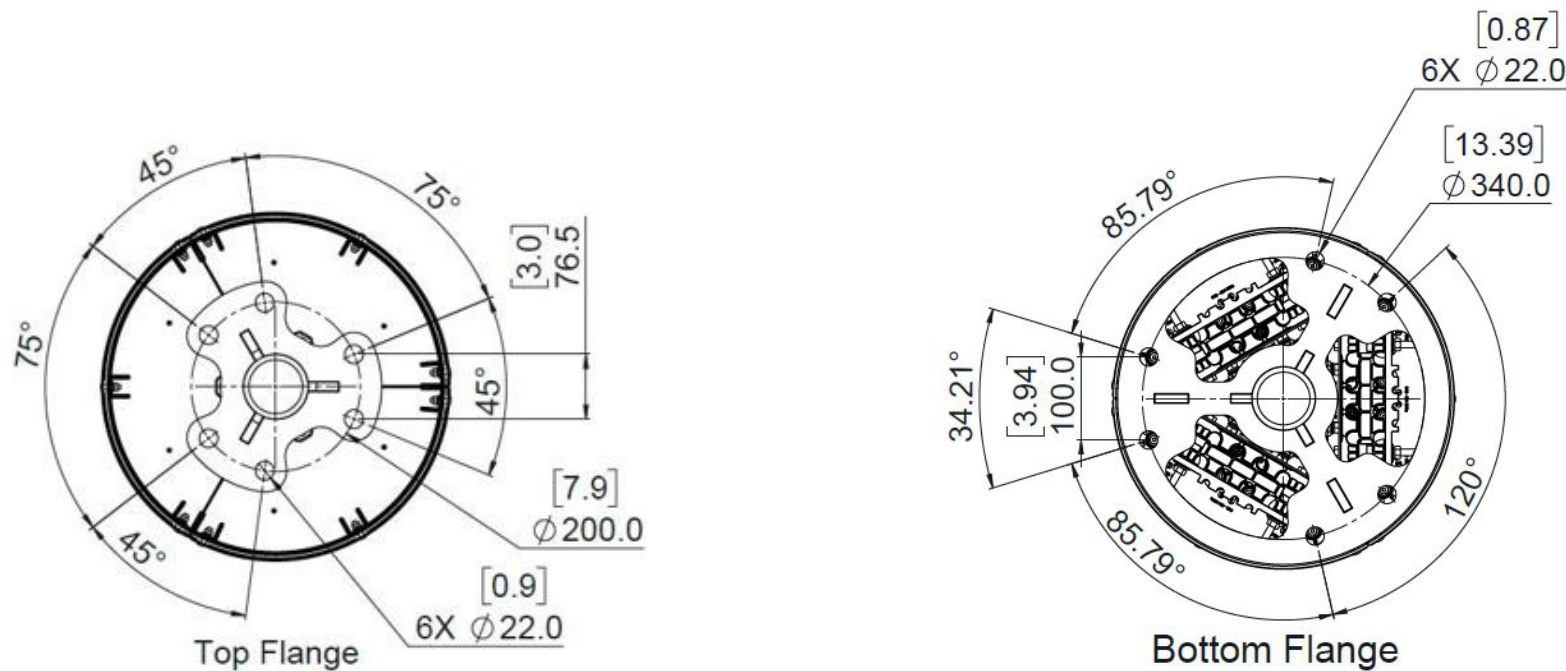

Mounting Kit Tilt Range	Mounting Kit Material	Mounting Kit Pole Diameter
0	Galvanized Steel	N/A

### Ordering Info

Order Code - Antenna	Description
AWT2-3927	Enclosed Remote Electrical Tilt (eRET) with 4.3-10 Connectors.
Order Code - Accessories	Description
AW1012-2-FM-NM	RF Jumper Cable, connector types 4.3-10 (m) / N-Type (m), length 2 metres (6'6")
AW1014-2-FM-TM	RF Jumper Cable, connector types 4.3-10 (m) / Nex10 (m), length 2 metres (6'6")
PADC 1000	Portable AISG Controller
AW0326-3-PM-PF	AISG Jumper Cable Lengths 3 metres (9' 10")
AW0326-10-PM-PF	AISG Jumper Cable Lengths 10 metres (32' 9")

### Enquiries

**Global Headquarters**  
Ashgrove Business Centre,  
Ballybrittas, Portlaoise,  
R32 DTOA, IRELAND  
[sales@alphawireless.com](mailto:sales@alphawireless.com)  
+353 57 86 33847

**North America**  
7301 W. 129th Street, Suite 150,  
Overland Park,  
KS 66213, USA  
[sales@alphawireless.com](mailto:sales@alphawireless.com)  
+1 913 279 0008

**Australia**  
3/76 Regentville Rd,  
Jamisontown,  
NSW 2750, AUSTRALIA  
[sales@alphawireless.com](mailto:sales@alphawireless.com)  
+ 61 2 4504 8212

### DISCLAIMER

The information in this document is provided solely regarding Alpha Wireless products. The information is not a guarantee of performance or characteristics. Alpha Wireless reserves the right to modify, change, amend, improve or make corrections to this document and its products, at any time and its sole discretion without prior written consent or notice. No license to any intellectual property rights is granted or implied under this document. Alpha Wireless disclaims warranties and liabilities of any kind including non-infringement of intellectual property rights of any third party.

© Alpha Wireless Limited 2022