



AWT2-4106

Common Name 18 Port (2P/4P x 3) 1.9M Low Band, L-Band / Mid Band Modular Tri-Sector, T2 Series

698-960MHz	6	eRET	15.0	69°
1427-2690MHz	12	eRET	17.8	62°
Frequency	Ports	Tilt	Gain	Beamwidth

PRODUCT INFORMATION

Stack	Part Name	Description
B1	Base Stack	This is the antenna stack supplied with the AWT2-4106. There is a Mount Plate located on the bottom of the Base Stack to attach to the Monopole.
X2	Extension Stack	This antenna stack is not supplied with the AWT2-4106. It can be bought at a later date and mounted on top of the Base Stack if additional capacity is required.

The Modular Tri-Sector T2 Series is a flexible antenna platform designed for Streetwork deployments. The AWT2 Platform is made up using discrete parts. The AWT2-4106 consists of two modular antenna stacks which are detailed in the table below:

Stack Type	Frequency Bands	Ports per Stack
Base Stack	698-960MHz	6
	1427-2690MHz	12

Each stack is made up of three panels that are positioned at 0°, 120° and 240° in the Azimuth plane. These individual panels are replaceable in the field for upgrade or maintenance purposes.

Note #1: The Alpha Wireless AWT2 series can only support a single Base Stack and a single Extension Stack. The Alpha Wireless AWT4 series can support a single Base Stack and up to three Extension Stacks.

Note #2: Both the AWT2 and AWT4 have a mounting plate to enable mounting number of Active Antenna units on top, weight permitting.

APPLICATION

Sector antennas support multiple antennas into one attractive package. These canisters deliver an elegant macro solution for pole-top, rooftop and streetworks applications. Alpha Wireless produces one of the smallest diameter canisters in the marketplace.

STANDARD & CERTIFICATIONS

Certification	BS EN ISO 9001:2015
---------------	---------------------



FEATURES

- The AWT2 Series supports up to two modular stacks.
- Field upgradable sectors without decommissioning the other sectors.
- Three sector canister with sectors orientated at 0°, 120° and 240° in the Azimuth Plane
- 698-960MHz x 2 Ports per sector
- 1427-2690MHz x 4 Ports per sector
- 698-960MHz tilt range T2° - T12°.
- 1427-2690MHz tilt range T2° - T12°.
- Low PIM performance to reduce interference.

TECHNICAL SPECIFICATION

Electrical Specifications		Low Band			Mid Band				
Frequency Range	MHz	698-790	790-890	890-960	1427-1492	1695-1920	1920-2170	2300-2690	
Polarisation	Degree	+/- 45° Slant Linear			+/- 45° Slant Linear				
Gain	Basta	dB	13.8 ±0.5	14.5 ±0.5	14.5 ±0.5	15.8 ±0.5	16.6 ±0.5	17.1 ±0.5	17.3 ±0.5
	Max	dB	14.3	15.0	15.0	16.3	17.1	17.6	17.8
Azimuth Beamwidth	Degree	72°	69°	67°	72°	63°	62°	66°	
Elevation Beamwidth	Degree	16.2°	14.6°	13.4°	9.5°	7.5°	6.5°	5.5°	
Electrical Downtilt	Degree	T2° - T12°			T2° - T12°				
Electrical Downtilt Deviation	Degree<	1.5°	1.5°	1.5°	1.0°	1.0°	1.0°	1.0°	
Impedance	Ohms	50			50				
VSWR	<	1.5			1.5				
Return Loss	dB>	14			14				
Isolation	dB>	25	25	25	25	25	25	25	
Passive Intermodulation	dBc<	-150	-150	-150	-150	-150	-150	-150	
Upper Sidelobe Suppression, Peak to 20°	dB>	22	22	22	17	17	16	13	
Cross-Polar Discrimination at Boresight	dB>	15	15	15	15	15	15	15	
Max Power Per Port	W	300			250				

Radiation Pattern Files

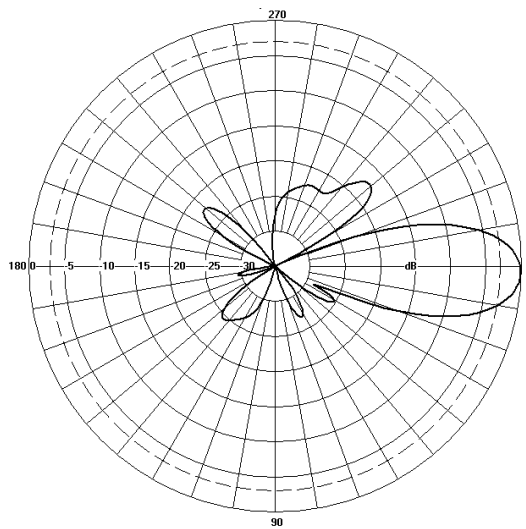
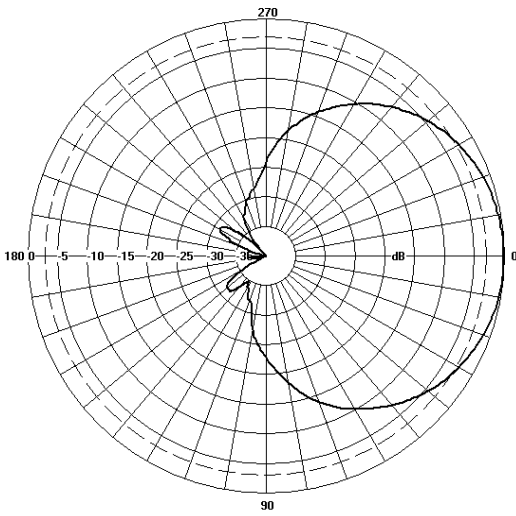

Low Band

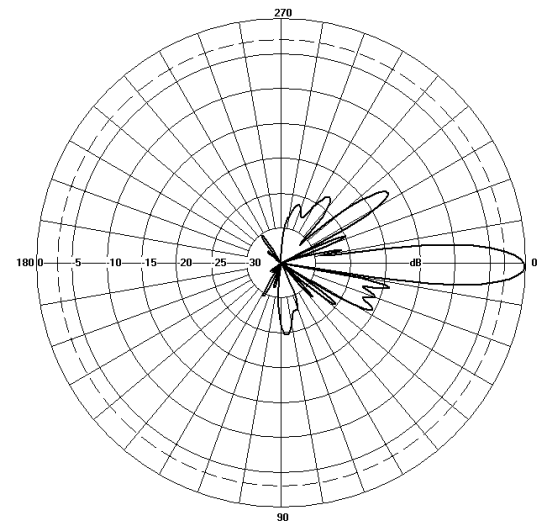

Mid Band

Azimuth

Elevation

For radiation pattern files, please login at www.alphawireless.com

TECHNICAL SPECIFICATION

Mechanical Specifications

Dimensions Base (Length x Diameter)	mm (in)	1911 (75.3) x 406 (16) - (L x Ø)
Weight of Base Stack	kg (lb)	96.5
Weight of Extension Stack	kg (lb)	74.5
Total Tri-Sector Weight	kg (lb)	171.0
Connector Type (Female)	-	4.3-10
Connector Position	-	Bottom
Connector Quantity	-	18 (6P Low Band, 12P Mid Band)
Windload Frontal (at Rated Wind Speed: 150km/h)	N (lbf)	640 (144)
Windload Lateral (at Rated Wind Speed: 150km/h)	N (lbf)	640 (144)
Survival Wind Speed	km/h (mph)	241 (150)
Radome Material	-	uPVC
Radome Colour	RAL	7035 (light grey)
Product Compliance Environmental	-	RoHS
Lightning Protection	-	DC Grounded
Cold Temperature Survival	°C (°F)	-40 (40)
Hot Temperature Survival	°C (°F)	70 (158)
Shipping Information	-	-
Size of Crate Type 1 - Base Stack and Interface (L x W x D)	mm (in)	2100 (82.6) x 570 (22.4) x 628 (24.7)
Shipping Weight of Crate Type 1 - Base Stack	kg (lb)	149 (327.8)

Array Layout and RET Information

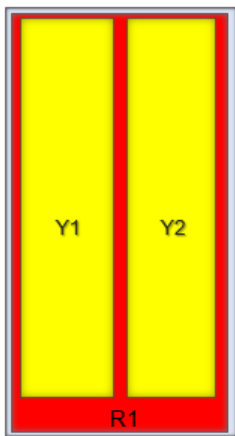

Array layout depicts one individual sector.
Note: Coloured box sizes do not represent antenna sizes.

Array	Frequency MHz	Ports	RET
R1	698 - 960	1 - 2	1
Y1	1427 - 2690	3 - 4	2
Y2	1427 - 2690	5 - 6	3

Configuration	
698-960 MHz	One RET per array: (R1) x 3 Sectors
1427-2690 MHz	One RET per pair of array: (Y1/Y2) x 3 Sectors
Total Quantity	9 RET Motor Controllers
Location and Interface	
RET Controller Location	Inside antenna radome housing
RET Interface	Pair of AISG 8 Pin DIN connectors, one male, one female
RET Interface Quantity	Three pairs of AISG 8 Pin DIN connectors, one per sector
RET Interface Location	On connector plate located at bottom of antenna
Electrical	
Input Voltage	10 - 30V
Power Idle Mode	< 1W
Power Active Mode	< 10W
Protocol	3GPP / AISG 2.0

TECHNICAL SPECIFICATION

Mechanical Drawings

Description of Parts	
Base Stack	This contains the Antenna Sectors. Mounted onto the Base Stack Interface. The top of the Base Stack has a mounting flange onto which either of the following can be mounted: 1. An Extension Stack or 2. A Mount bracket for Active Antenna units (AAUs, weight permitting), can be mounted.
Extension Stack	Note: The Extension Stack is not supplied with the AWT2-4106. The Extension Stack if required, can be ordered separately. At the top of the Extension Stack there is a mounting flange onto which a Mount Bracket for Active Antenna units (AAUs, weight permitting), can be mounted.
RF Jumper Base Stack	Feeders from the Radio Cabinet feed directly into the connectors located at the bottom of the Base Stack.
RF Jumpers Extension Stack	RF Jumpers are routed behind the Base Stack Radomes.

TECHNICAL SPECIFICATION

Tri-Sector Construction



Left Image showing one sector detached from each level of the 2 level assembly.

Each sector can be detached individually.

Right Image showing the single Internal Structure along with the Base Extension bolted onto the Base of the Internal Structure.

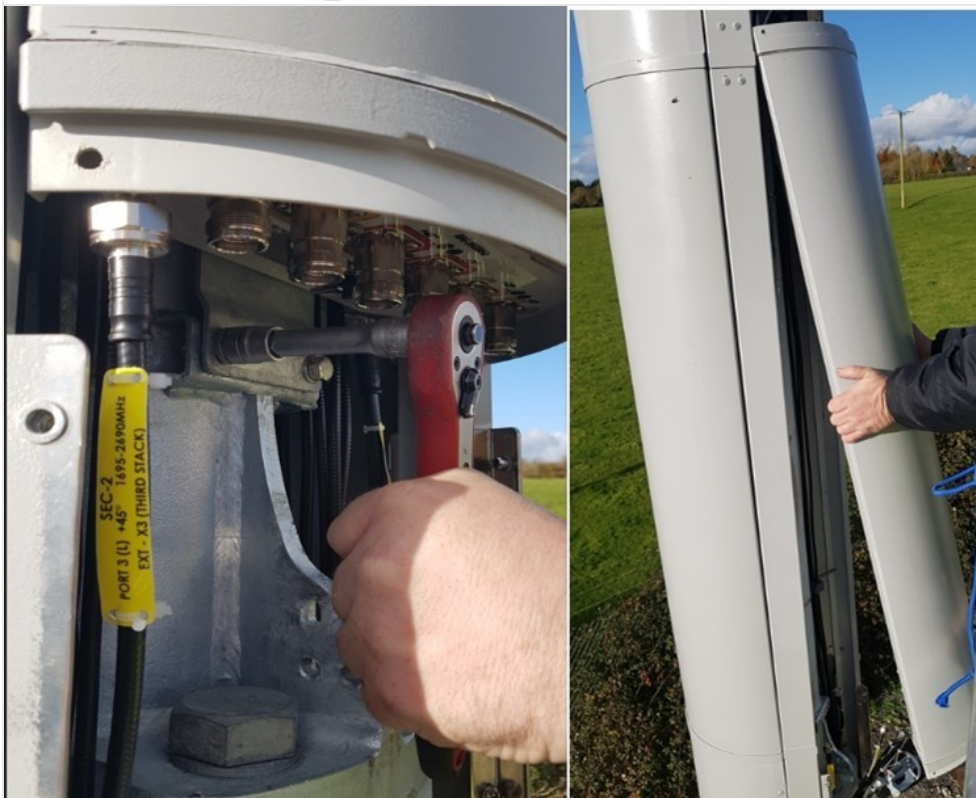

The sectors can be individually removed by undoing four bolts, two at the bottom and two at the top. The photo above left shows the two bolts securing the bracket at the bottom. The picture above right shows how the sector can be lifted off the internal structure and then replaced using the reverse process. Note The RF Jumper Cables and AISG Cables should be detached before removing the sector.

TECHNICAL SPECIFICATION

Cable Management

Hatch Cable Management
Bracket 1/2"

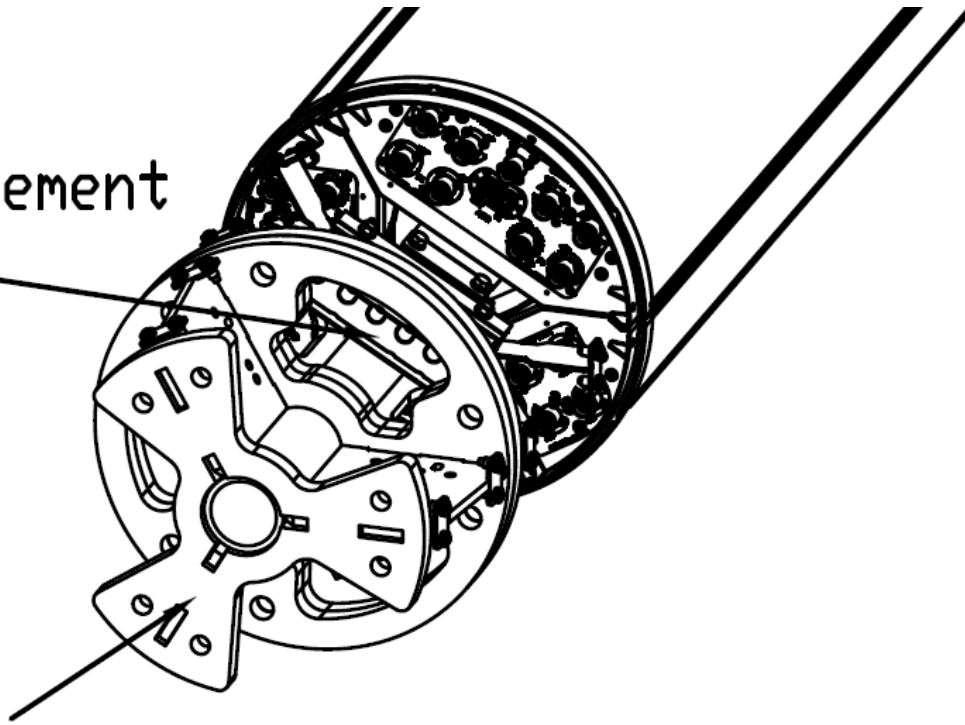

Base Stack Mount Plate

Quarter Inch RF Jumper Cables (4.3-10M - 4.3-10F) are routed from Sectors located in the upper extension stacks down to the bottom of the base stack. These are secured in the base with quarter inch cable clamps. There are cable clamps sized for 1/2" diameter cables positioned under the 1/4" cable clamp to secure cables coming up from the cabinet below. The intention is for the two cable diameters to be joined between the cable clamps.

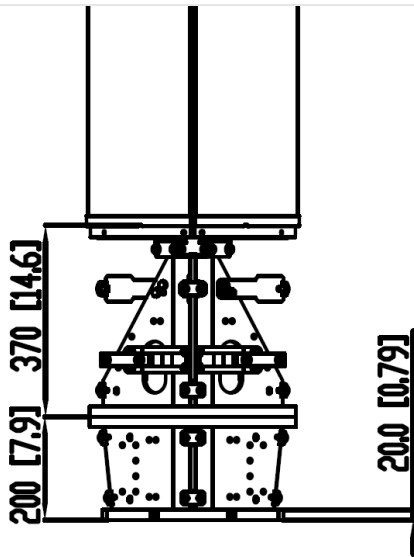

TECHNICAL SPECIFICATION

RF Jumper Cables

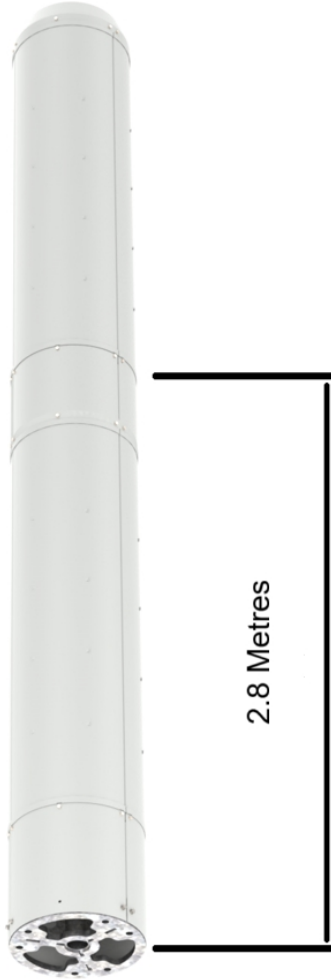

Part Number: AW1014-2-FM-FF-NB
Description: Jumper 4.3-10M – 4.3-10F,
 2M, ¼" Super Flexible PE (S)
Quantity: 18

Active Antenna Unit



An Active Antenna Unit (AAU) can be mounted on top of the Extension if required. A bracket will need to be designed and manufactured to fit the particular AAU selected by the customer. A drawing of the top plate can be provided upon request.

Power and Fiber connections can be routed between the base of the antenna and the top AAU mounting through the same channels used to route the RF Jumper Cables. The Power and Fiber cables can be routed through the Cable Clamps located in the channels alongside the RF Jumper Cables.

TECHNICAL SPECIFICATION

Connector Plate Images



View of the Full Connector Plate at the bottom of the Stack. Each Stack has the same connector plate.



View of the Connector Plate on a single Sector.



Each RET Motor is located at the bottom of each antenna sector as part of the Connector Plate. Each RET motor can be accessed individually and if necessary replaced individually by releasing two screws and sliding out the RET Motor Cartridge. A new RET Motor Cartridge can be slid back in as replacement.

TECHNICAL SPECIFICATION

Mount Flange Information

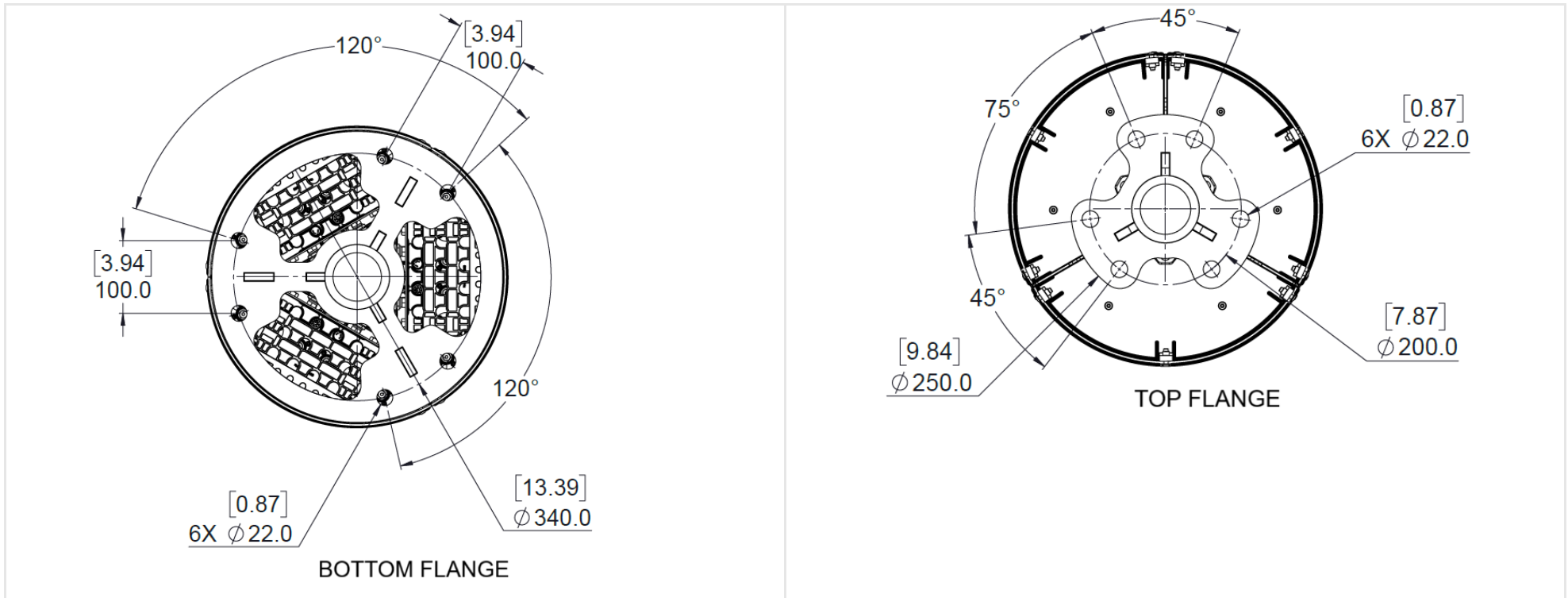

Mount Flange Attachment to Pole	Mounting Flange Material	Mount Flange Outer Diameter
6X Ø22.0 Bolts	Galvanised Steel	406mm

Ordering Info

Order Code - Antenna	Description
AWT2-4106	18 Port (2P/4P x 3) 1.9M Low Band, L-Band / Mid Band Modular Tri-Sector
Order Code - Accessories	Description
AW1012-2-FM-NM	RF Jumper Cable, connector types 4.3-10 (m) / N-Type (m), length 2 metres (6'6")
AW1014-2-FM-TM	RF Jumper Cable, connector types 4.3-10 (m) / Nex10 (m), length 2 metres (6'6")
PADC 1000	Portable AISG Controller
SADC 2000	Site AISG Controller
AW0326-3-PM-PF	AISG Jumper Cable Lengths 3 metres (9' 10")
AW0326-10-PM-PF	AISG Jumper Cable Lengths 10 metres (32' 9")

Enquiries

Global Headquarters
 Ashgrove Business Centre,
 Ballybrittas, Portlaoise,
 R32 DTOA, IRELAND
sales@alphawireless.com
 +353 57 86 33847

North America
 7301 W. 129th Street, Suite 150,
 Overland Park,
 KS 66213, USA
sales@alphawireless.com
 +1 913 279 0008

Australia
 3/76 Regentville Rd,
 Jamisontown,
 NSW 2750, AUSTRALIA
sales@alphawireless.com
 + 61 2 4504 8212

DISCLAIMER

The information in this document is provided solely regarding Alpha Wireless products. The information is not a guarantee of performance or characteristics. Alpha Wireless reserves the right to modify, change, amend, improve or make corrections to this document and its products, at any time and its sole discretion without prior written consent or notice. No license to any intellectual property rights is granted or implied under this document. Alpha Wireless disclaims warranties and liabilities of any kind including non-infringement of intellectual property rights of any third party.