



AW3883-E-F

Common Name 8 Port (4P/4P) 1.3M Dual Band Panel

1710-2690MHz	4	eRET	18.0	65°
3300-3800MHz	4	eRET	18.0	65°
Frequency	Ports	Tilt	Gain	Beamwidth

PRODUCT INFORMATION

This product was designed to offer Mid-band as well as 3.5GHz functionality operating between 3300-3800MHz covering LTE Bands B42, 43 & 48 and 5G NR Band n78 in a compact housing for multi-operator applications. This design is intended to offer 4 ports on Mid Band and 4 ports on 3.5GHz (CBRS).

APPLICATION

Alpha Wireless panel antennas provide wireless network operators the highest performance and quality. Panel antennas are generally used in sectorized applications. These antennas are designed for optimal radiation patterns improving overall network performance. A horizontally spaced array provides enhance MIMO performance with full 4x4 operation or receive diversity RF functions. This very special antenna provides 4G to 5G ports for ultimate data throughput.



STANDARD & CERTIFICATIONS

Certification	BS EN ISO 9001:2015
---------------	---------------------



FEATURES

- Multi-band antenna 1710 - 2690/ 3300 - 3800MHz.
- 4x4 MIMO for each band for maximum throughput.
- 1710-2690MHz tilt range T0°-T10°
- 3300-3800Mhz tilt range T0°-T10°
- Wide-band antenna that covers LTE Bands 42, 43 & 48 and 5G NR Band n78. Includes CBRS Band.
- Compact design for low visual impact.

The parameters in this specification follow the definitions and recommendations per NGMN P-Basta, Release 9.6.

TECHNICAL SPECIFICATION

Electrical Specifications								
Frequency Range	MHz	1710-1995	1920-2170	2170-2500	2500-2690	3300-3600	3600-3800	
Polarisation	Degree	+/- 45° Slant Linear						
Gain	Basta	dBi	16.8±0.5	17.1±0.5	17.3±0.5	17.5±0.5	17.3±0.5	17.5±0.5
	Max	dBi	17.3	17.6	17.8	18.0	17.8	18.0
Azimuth Beamwidth	Degree	67°	65°	64°	60°	65°	60°	
Azimuth Beam Squint	Degree<	5°						
Elevation Beamwidth	Degree	7.5°	6.8°	6.3°	5.8°	7.0°	6.6°	
Electrical Downtilt	Degree	T0° - T10°	T0° - T10°	T0° - T10°	T0° - T10°	T0° - T10°	T0° - T10°	
Electrical Downtilt Deviation	Degree<	1.0°	1.0°	1.0°	1.0°	1.0°	1.0°	
Impedance	Ohms	50						
VSWR	<	1.5						
Return Loss	dB>	14						
Intraband Isolation (same band/same array)	dB>	25	25	25	25	25	25	
Network to Network Isolation (same band different array)	dB>	25	25	25	25	30	30	
Interband Isolation (different band and array)	dB	28	28	28	28	28	28	
Front to Back Ratio: Total Power +/-30°	dB>	25	25	25	25	25	25	
Passive Intermodulation	dBc<	-153	-153	-153	-153	-	-	
Cross-Polar Discrimination (0°)	dB>	16	16	16	16	16	16	
Maximum Effective Power Per Port	W	200	200	200	200	150	150	

Representative Pattern Files

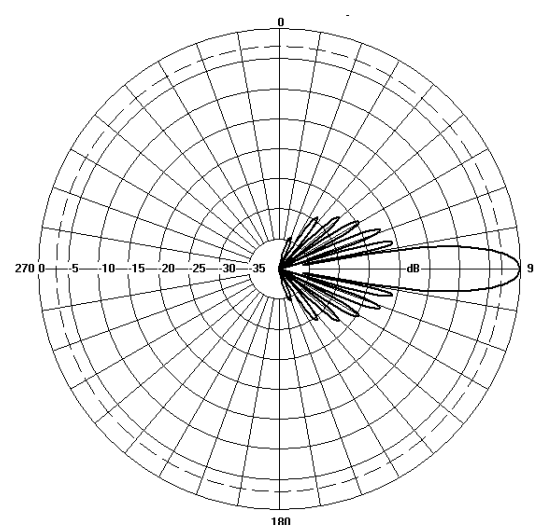
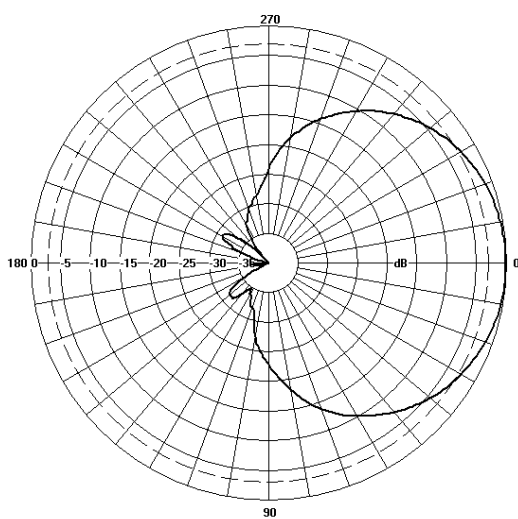

1710 - 2690MHz

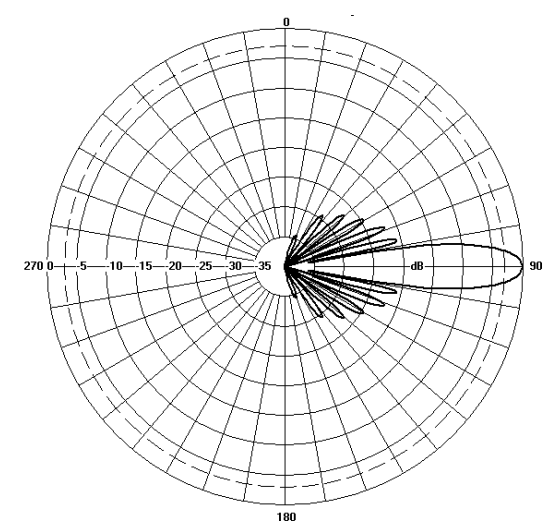

3300 - 3800MHz

Azimuth

Elevation

For radiation pattern files, please login at www.alphawireless.com

TECHNICAL SPECIFICATION

Mechanical Specifications

Dimensions	mm (in)	1350 (52.1) x 470 (18.5) x 115 (4.5) - (LxWxD)
Packing Size (LxWxD)	mm (in)	1560 (61.4) x 600 (23.6) x 310 (12.5) - (LxWxD)
Net Weight (antenna)	kg (lb)	20 (44.1)
Net Weight (mount)	kg (lb)	3.1 (6.8)
Shipping Weight	kg (lb)	29.5 (65)
Connector Type (Female)	-	4.3-10
Connector Position	-	Bottom
Connector Quantity	-	8 (4P Mid Band, 4P High Band 3.5GHz (CBRS))
Windload Frontal (at Rated Wind Speed: 150km/h)	N	485 (109)
Windload Lateral (at Rated Wind Speed: 150km/h)	N	95 (21)
Survival Wind Speed	km/h (mph)	200 (125)
Radome Material	-	Fibreglass
Radome Colour	-	Light Grey
Product Compliance Environmental	-	RoHS
Lightning Protection	-	DC Grounded
Cold Temperature Survival	Celsius (Fahrenheit)	-40 (-40)
Hot Temperature Survival	Celsius (Fahrenheit)	70 (158)

Array Layout and RET Information

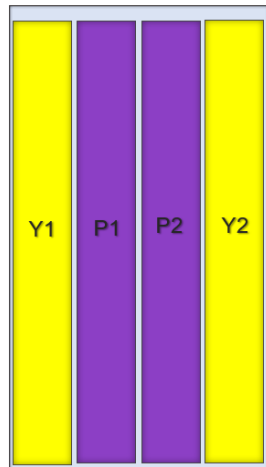

Note: Coloured box sizes do not represent antenna sizes.

Array	Frequency MHz	Ports	RET ID
Y1	1710 - 2690	1 - 2	1
Y2	1710 - 2690	3 - 4	1
P1	3300 - 3800	5 - 6	2
P2	3300 - 3800	7 - 8	2

Configuration	
1710-2690 MHz	One RET controls both arrays: Y1, Y2
3300-3800 MHz	One RET controls both arrays: P1, P2
Total Quantity	Two RET Motor Controllers
Location and Interface	
RET Controller Location	Inside antenna radome housing
RET Interface	Pair of AISG 8 Pin DIN connectors, one male, one female
RET Interface Quantity	One pair of AISG 8 Pin DIN connectors
RET Interface Location	On connector plate located at bottom of antenna
Electrical	
Input Voltage	10 - 30V
Power Idle Mode	< 1W
Power Active Mode	< 10W
Protocol	3GPP / AISG 2.0

Mechanical Illustration

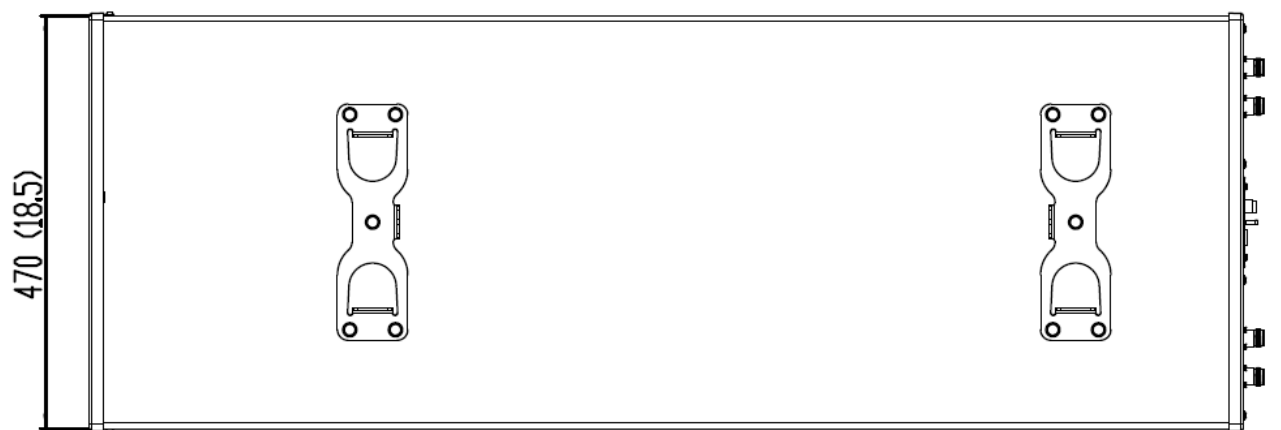
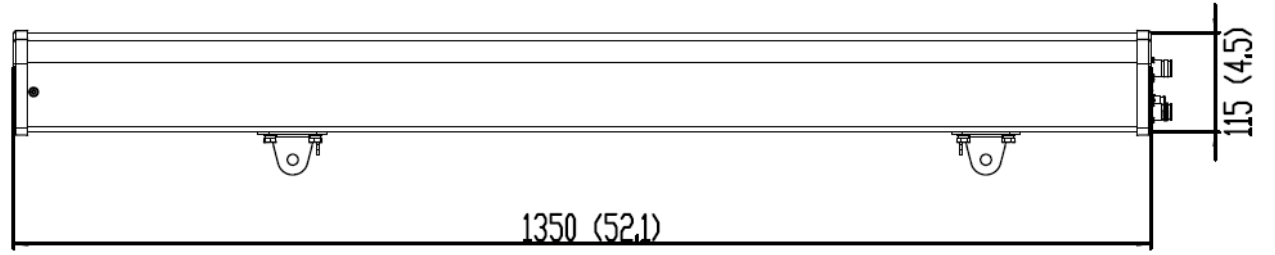
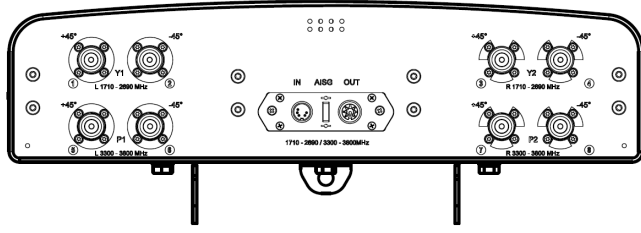

CL-V-110 Mount Kit (Mount Kit included with antenna)

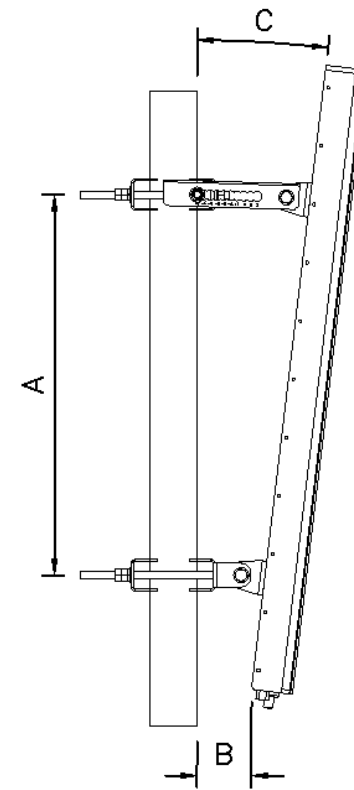
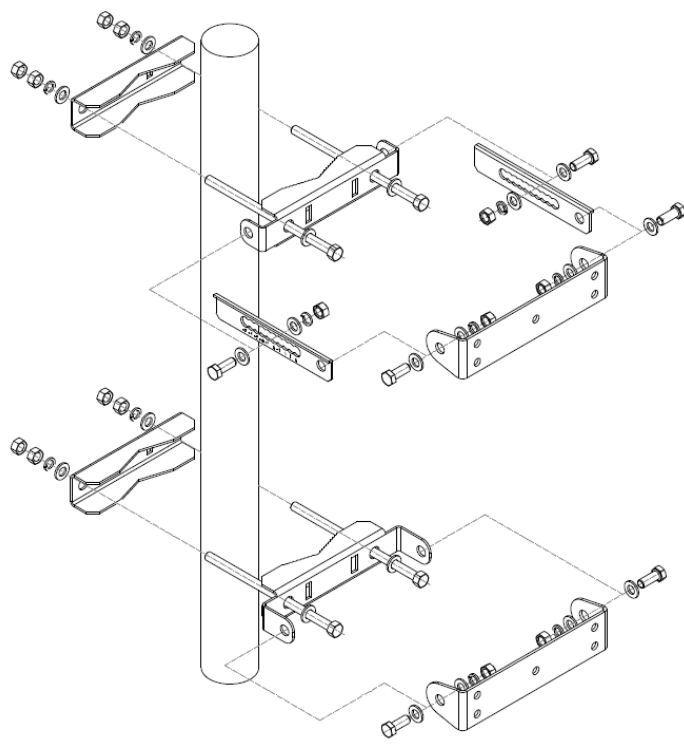

Mounting Kit Tilt Range	Mounting Kit Material	Mounting Kit Pole Diameter
+1° to -7°	Stainless Steel	50mm-115mm (2" to 4.5")

Ordering Info

Order Code - Antenna

AW3883-E-F

Description

Enclosed Remote Electrical Tilt (eRET) with 4.3-10 Connectors.

Order Code - Accessories

AW1012-2-FM-FM

Description

RF Jumper Cable, connector types 4.3-10 (m) / 4.3-10 (m), length 2 metres (6'6")

AW1012-2-FM-NM

RF Jumper Cable, connector types 4.3-10 (m) / N-Type (m), length 2 metres (6'6")

AW1014-2-FM-TM

RF Jumper Cable, connector types 4.3-10 (m) / Nex10 (m), length 2 metres (6'6")

Enquiries

Global Headquarters

Ashgrove Business Centre,
Ballybrittas, Portlaoise,
R32 DT0A, IRELAND
sales@alphawireless.com
+353 57 86 33847

North America

7301 W. 129th Street, Suite 150,
Overland Park,
KS 66213, USA
sales@alphawireless.com
+1 913 279 0008

Australia

3/76 Regentville Rd,
Jamisontown,
NSW 2750, AUSTRALIA
sales@alphawireless.com
+ 61 2 4504 8212

DISCLAIMER

The information in this document is provided solely regarding Alpha Wireless products. The information is not a guarantee of performance or characteristics. Alpha Wireless reserves the right to modify, change, amend, improve or make corrections to this document and its products, at any time and its sole discretion without prior written consent or notice. No license to any intellectual property rights is granted or implied under this document. Alpha Wireless disclaims warranties and liabilities of any kind including non-infringement of intellectual property rights of any third party.

© Alpha Wireless Limited 2022