



AWT2-3871

Common Name 36 Port (4P/8P x 3) 3.6M Low Band, Mid Band Modular Tri-Sector, T2 Series.

698-960MHz	12	eRET	15.0	70°
1710-2690MHz	24	eRET	17.8	65°
Frequency	Ports	Tilt	Gain	Beamwidth

PRODUCT INFORMATION

The Alpha Wireless Modular Tri-Sector T2 Series is a flexible antenna platform designed for Streetwork deployments. The AWT2 Platform is made up using discrete parts:

Part	Part Name	Description
1	The Base Stack Interface.	Is used to attach the Base Stack to the Monopole. It is attached to the Base Stack in the factory.
2	The Base Stack.	This is the lower of the two antenna modules.
3	The Extension Stack	This is the upper of the two antenna modules.

The AWT2-3871 consists of two modular antenna stacks which are detailed in the table below:

Stack Type	Frequency Bands	Ports per Stack
Base Stack	698-960MHz	6
	1710-2690MHz	12
Extension Stack	698-960MHz	6
	1710-2690MHz	12

Each stack is made up of three panels that are positioned at 0°, 120° and 240° in the Azimuth plane. These individual panels are replaceable in the field for upgrade or maintenance purposes.

Important: The Alpha Wireless AWT2 series can only support a single Base Stack and a single Extension Stack. The Alpha Wireless AWT4 series can support a single Base Stack and up to three Extension Stacks.

APPLICATION

Sector antennas support multiple antennas into one attractive package. These canisters deliver an elegant macro solution for pole-top, rooftop and streetworks applications. Modular Tri-sector antennas allow upgrading a site beyond the initial deployment with minimal cost and disruption. Alpha Wireless produces one of the smallest diameter canisters in the marketplace.

STANDARD & CERTIFICATIONS

Certification BS EN ISO 9001:2015

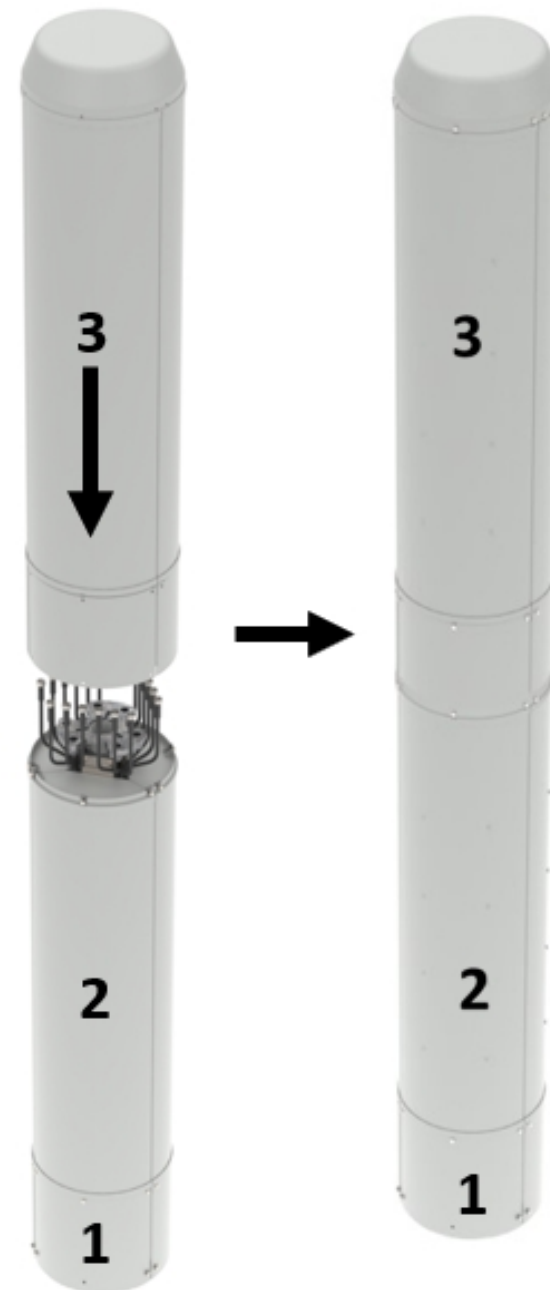

FEATURES

- The AWT2 Series supports up to two modular stacks.
- Field upgradable sectors without decommissioning the other sectors.
- Three sector canister with sectors orientated at 0°, 120° and 240° in the Azimuth Plane.
- 698-960MHz x 2 Ports per sector.
- 1710-2690MHz x 4 Ports per sector.
- 698-960MHz tilt range T2° - T12°.
- 1710-2690MHz tilt range T2° - T12°.
- Low PIM performance to reduce interference.

The parameters in this specification follow the definitions and recommendations per NGMN P-Basta, Release 9.6.

TECHNICAL SPECIFICATION

Electrical Specifications		Low Band			Mid Band			
Frequency Range	MHz	698-960	790-890	890-950	1710-1920	1920-2170	2300-2690	
Polarisation	Degree	+/- 45° Slant Linear						
Gain	Basta	dBi	13.8 ±0.5	14.2 ±0.5	14.5 ±0.5	16.8 ±0.5	17.1 ±0.5	17.3 ±0.5
	Max	dBi	14.3	14.7	15.0	17.3	17.6	17.8
Azimuth Beamwidth	Degree	71°	68°	67°	64°	64°	65°	
Azimuth Beam Squint	Degree<	5°			5°			
Elevation Beamwidth	Degree	16.5°	15.0°	13.8°	7.5°	6.7°	5.7°	
Electrical Downtilt	Degree	T2° - T12°			T2° - T12°			
Electrical Downtilt Deviation	Degree<	1°	1°	1°	1°	1°	1°	
Impedance	Ohms	50						
VSWR	<	1.5						
Return Loss	dB>	14						
Isolation	dB>	25	25	25	25	25	25	
Passive Intermodulation	dBc<	-150	-150	-150	-150	-150	-150	
Upper Sidelobe Suppression, Peak to 20°	dB>	15	15	15	15	15	15	
Cross-Polar Discrimination	dB>	15	15	15	15	15	15	
Max Power Per Port	W	300			250			

Representative Pattern Files

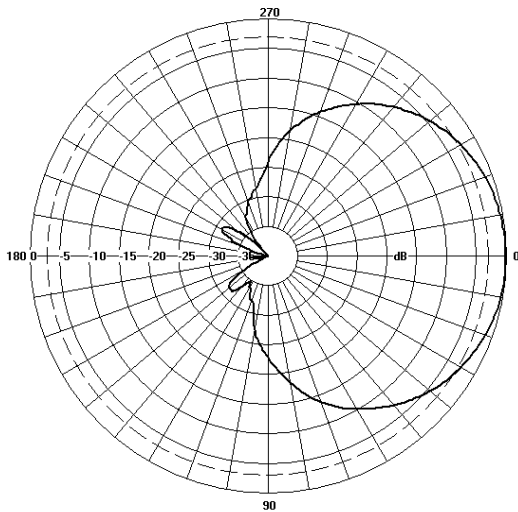

Azimuth

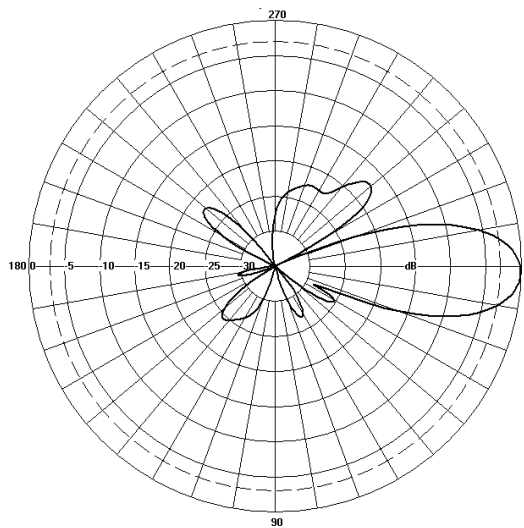

Low Band

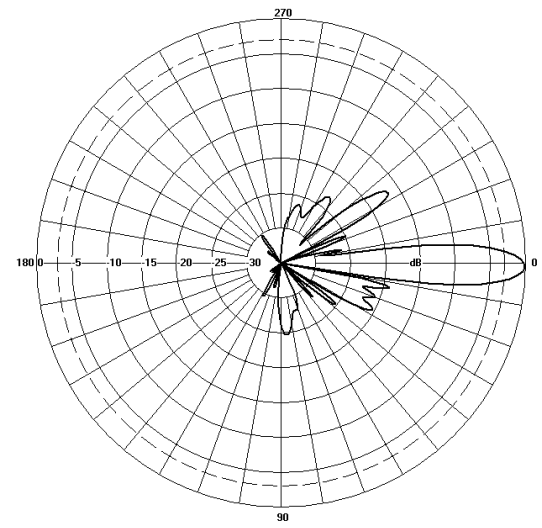

Mid Band

Elevation

For radiation pattern files, please login at www.alphawireless.com

TECHNICAL SPECIFICATION

Mechanical Specifications

Total Tri-Sector Dimensions	mm (in)	3614 (142.3) x 406 (16) - (L x Ø)
Size of Crate 1 - Base Stack and Interface (LxWxD)	mm (in)	2100 (82.6) x 570 (22.4) x 628 (24.7)
Size of Crate 2 - Extension Stack (LxWxD)	mm (in)	2100 (82.6) x 570 (22.4) x 628 (24.7)
Weight of Crate 1 - Base Stack and Interface	kg (lb)	149 (327.8)
Weight of Crate 2 - Extension Stack	kg (lb)	127 (279.4)
Weight of Base Interface and Base Stack (1 & 2)	kg (lb)	96.5 (212.3)
Weight of Extension Stack (3)	kg (lb)	74.5 (163.9)
Connector Type (Female)	-	4.3-10
Connector Position	-	Bottom
Connector Quantity	-	36 (12P Low Band, 24P Mid Band)
Windload Frontal (at Rated Wind Speed: 150km/h)	N (lbf)	1194 (270)
Windload Lateral (at Rated Wind Speed: 150km/h)	N (lbf)	1194 (270)
Survival Wind Speed	km/h (mph)	200 (125)
Radome Material	-	UV Stabilised ASA capped ABS
Radome Colour	RAL	7035 (light grey)
Product Compliance Environmental	-	RoHS
Lightning Protection	-	DC Grounded
Cold Temperature Survival	Celsius (Fahrenheit)	-40 (-40)
Hot Temperature Survival	Celsius (Fahrenheit)	70 (158)

Array Layout and RET Information

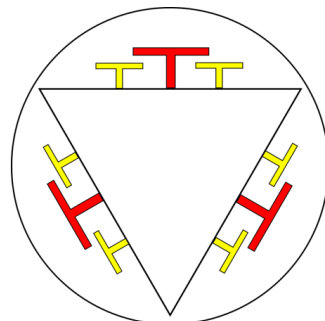
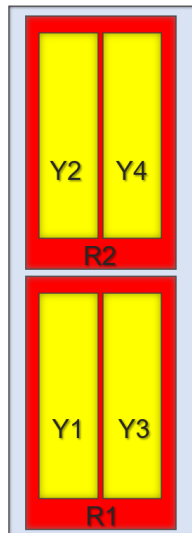

Array layout depicts one individual sector.
Note: Coloured box sizes do not represent antenna sizes.

Array	Frequency MHz	Ports	RET ID
R1	698 – 960	1 – 2	1
R2	698 – 960	3 – 4	2
Y1	1710 – 2690	5 – 6	3
Y2	1710 – 2690	7 – 8	4
Y3	1710 – 2690	9 – 10	5
Y4	1710 – 2690	11 – 12	6

Configuration	
698-960 MHz	One RET per array: R1, R2 x 3 Sectors
1710-2690 MHz	One RET per array: Y1, Y2, Y3, Y4 x 3 Sectors
Total Quantity	Eighteen RET Motor Controllers
Location and Interface	
RET Controller Location	Inside antenna radome housing
RET Interface	Pair of AISG 8 Pin DIN connectors, one male, one female
RET Interface Quantity	Three pairs of AISG 8 Pin DIN connectors, one per sector
RET Interface Location	On connector plate located at bottom of antenna
Electrical	
Input Voltage	10 – 30V
Power Idle Mode	< 1W
Power Active Mode	< 10W
Protocol	3GPP / AISG 2.0

TECHNICAL SPECIFICATION

Mechanical Illustration

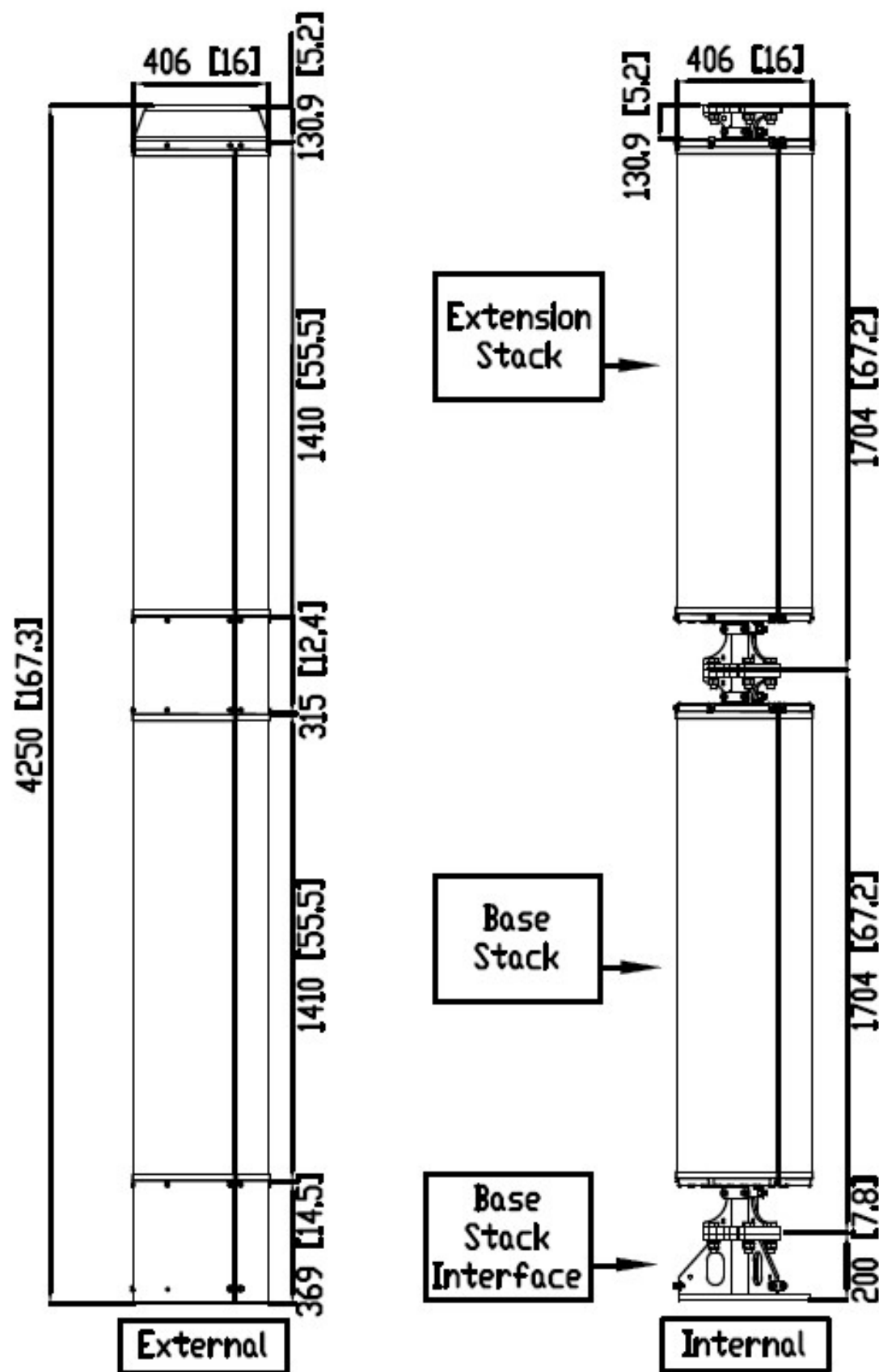

Description of Parts

Base Stack Interface	Used as an interface between the Base Stack and the Monopole.
Base Stack	This contains the Antenna Sectors. Mounted onto the Base Stack Interface. The top of the Base Stack has a mounting flange onto which an optional Extension Stack may be mounted.
Extension Stack	This is the upper stack that contains Antenna Sectors. It is mounted onto the flange plate located at the top of Base Stack.
RF Jumpers Base Stack	This contains the Antenna Sectors. Mounted onto the Base Stack Interface. The top of the Base Stack has a mounting flange onto which an optional Extension Stack may be mounted.
RF Jumpers Extension Stack	RF Jumpers are routed from the Base Stack Interface area up to the Connectors located on the bottom of the Extension Stack. The RF Jumpers are routed behind the Base Stack Radomes.

TECHNICAL SPECIFICATION

Mounting Bracket Kit

406mm Canister Flange Mount

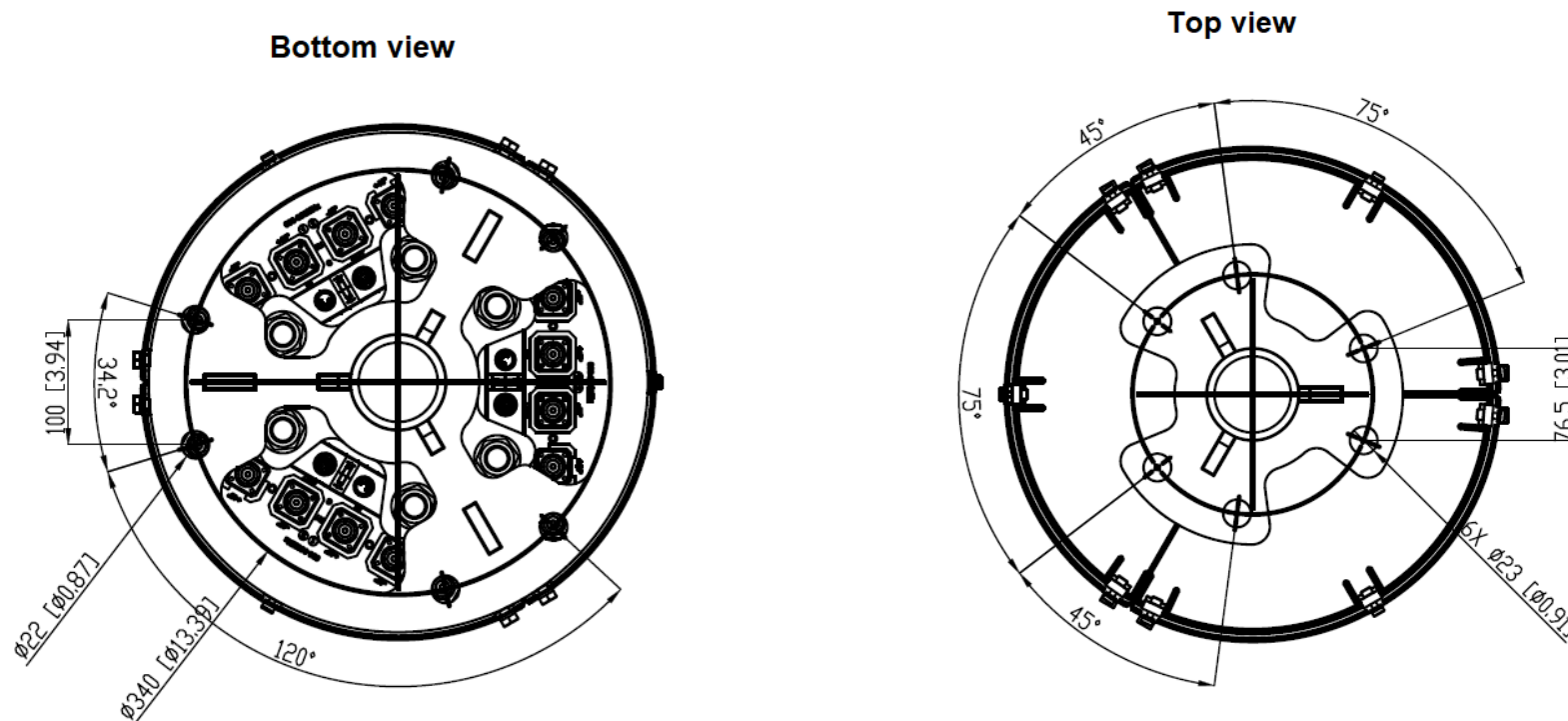

Mounting Kit Tilt Range	Mounting Kit Material	Mounting Kit Pole Diameter
0	Galvanized Steel	N/A

Ordering Info

Order Code - Antenna	Description
AWT2-3871	36 Ports (4P/8Px3), 698-960/1695-2690MHz, 14/17dBi
Order Code - Accessories	Description
AW1012-2-FM-FM	RF Jumper Cable, connector types 4.3-10 (m) / 4.3-10 (m), length 2 metres (6'6")
AW1012-2-FM-NM	RF Jumper Cable, connector types 4.3-10 (m) / N-Type (m), length 2 metres (6'6")
AW1014-2-FM-TM	RF Jumper Cable, connector types 4.3-10 (m) / Nex10 (m), length 2 metres (6'6")
PADC 1000	Portable AISG Controller
SADC 2000	Site AISG Controller
AW0326-3-PM-PF	AISG Jumper Cable Lengths 3 metres (9' 10")
AW0326-10-PM-PF	AISG Jumper Cable Lengths 10 metres (32' 9")
AW0326-25-PM-PF	AISG Jumper Cable Lengths 25 metres (82')
AW0326-50-PM-PF	AISG Jumper Cable Lengths 50 metres (164')

Enquiries

Global Headquarters
Ashgrove Business Centre,
Ballybrittas, Portlaoise,
R32 DTOA, IRELAND
sales@alphawireless.com
+353 57 86 33847

North America
7301 W. 129th Street, Suite 150,
Overland Park,
KS 66213, USA
sales@alphawireless.com
+1 913 279 0008

Australia
3/76 Regentville Rd,
Jamisontown,
NSW 2750, AUSTRALIA
sales@alphawireless.com
+ 61 2 4504 8212

DISCLAIMER

The information in this document is provided solely regarding Alpha Wireless products. The information is not a guarantee of performance or characteristics. Alpha Wireless reserves the right to modify, change, amend, improve or make corrections to this document and its products, at any time and its sole discretion without prior written consent or notice. No license to any intellectual property rights is granted or implied under this document. Alpha Wireless disclaims warranties and liabilities of any kind including non-infringement of intellectual property rights of any third party.

© Alpha Wireless Limited 2022